

9.0.3 Maintenance Hatz - 4H5 TICD

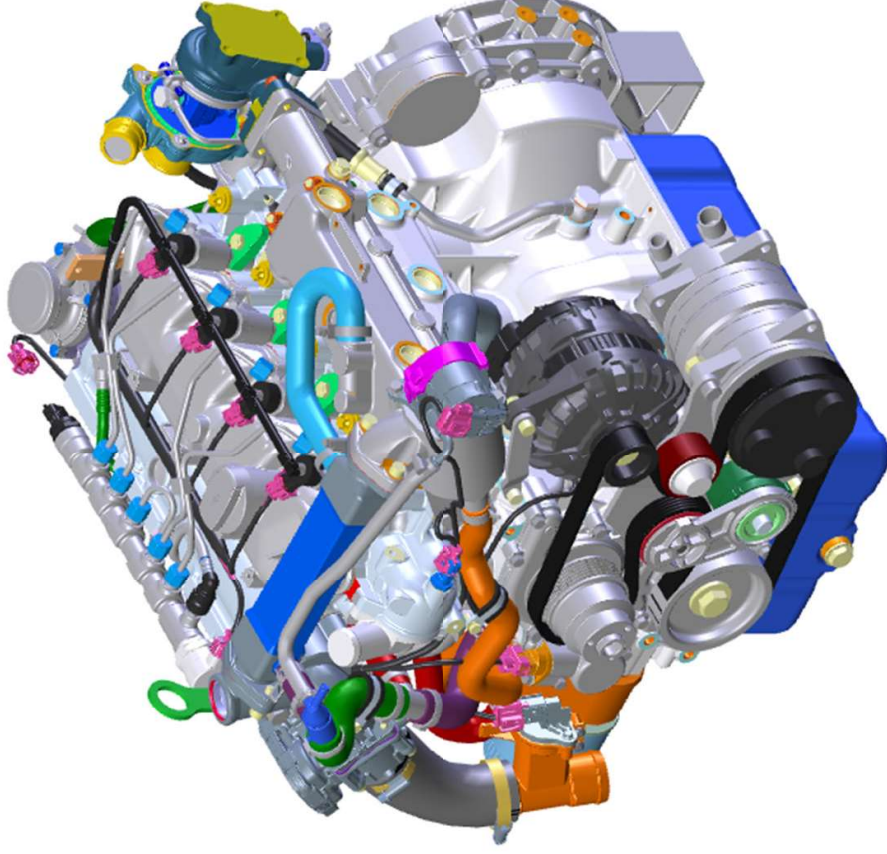

Note: This document is used to provide an overview of the system. For diagnosis and repair work on the Hatz engine, it is absolutely necessary that the Hatz Diagnostics software, error message list and the workshop manual are available.

Maintenance engine

table of contents



Maintenance intervals	3-4
Oil level Check	5
Oil and fuel filter change	6
Oil change	7
Emptying/changing fuel pre-filter	8
Check crankcase venting / Change oil separator	9
Change air filter and safety element	10
Check and change Poly-V belts	11
Coolant change	12-15
Check engine bearings	16-17
Check tightening moments	18-20
AGR system clean	21-22



Maintenance intervals motor

Every 8-15 operating hours or before the daily start	<p>Check oil level</p> <p>Check the intake area of the combustion air</p> <p>Check radiator fins for contamination</p> <p>Checking the cooling system</p>
Once after 50 hours of operation	<p>Engine oil and oil filter changes</p> <p>Change fuel filters</p> <p>Emptying the water separator of the fuel system</p> <p>Check coolant hoses and coolers</p> <p>Check engine bearings for damage and cracks</p> <p>V-ribbed belts check for condition and function</p> <p>Check the generator for contamination, clean it if necessary</p> <p>Check ECO, standard and maximum speed</p> <p>Check exhaust system for function and tightness</p> <p>Check fuel lines for function and tightness</p> <p>Check the air intake line for function and tightness</p>
Once after 250 hours of operation	<p>Read out the fault memory of the engine control unit, delete sporadic errors, repair unique errors if necessary</p> <p>Check the load status of the diesel particulate filter, perform a service regeneration if necessary</p> <p>Check engine oil level, refill if necessary</p> <p>Check coolant hoses and coolers for leaky ness</p> <p>Check the engine coolant, refill it if necessary. Refill only distilled water or engine coolant</p> <p>Combine cooler and radiator grille check for contamination, clean with compressed air if necessary</p> <p>Check engine bearings for damage, cracks and fixed seat</p> <p>Check V-ribbed belts for condition and function</p> <p>Check the generator for contamination, clean it if necessary</p> <p>Check exhaust system for function and tightness</p> <p>Check fuel lines for function and tightness</p> <p>Check air intake lines for function and tightness</p>



Wartungsintervalle Motor

Every 500 operating hours or every 2 years	<p>Change engine oil and oil filter</p> <p>Change fuel pre-filter</p> <p>Check Poly V belts</p> <p>Check the oil separator of the crankcase vent</p> <p>Check bolted connections</p> <p>Cleaning the engine</p> <p>Emptying the water separator of the fuel system</p> <p>Check coolant hoses and coolers</p> <p>Check the coolant in the compensating container, refill it if necessary</p> <p>Combine cooler and radiator grille check for contamination, clean with compressed air if necessary</p> <p>Check engine bearings for damage and cracks</p> <p>Check the generator for contamination, clean it if necessary</p> <p>Check ECO, standard and maximum speed</p> <p>Check exhaust system for function and tightness</p> <p>Check fuel lines for function and tightness</p> <p>Check the air intake line for function and tightness</p> <p>service regeneration of the diesel particulate filter.</p> <p>Change air filter cartridge</p>
Every 1000 operating hours in addition	Change security patrols (air filter secondary)
After notification or at the latest every 2 years	Drainwater separators
Every 4 years	Changing cooling fluid
If necessary, no later than every 3000 operating hours	Replace Poly V belt
Every 4000 operating hours	Clean the entire recirculation (AGR) (AGR pre-cooler, AGR valve, AGR main cooler and AGR mixing nozzle) (To be carried out by trained personnel)

Maintenance engine

Check oil level if necessary refill (daily) and change (50h and every 500h)

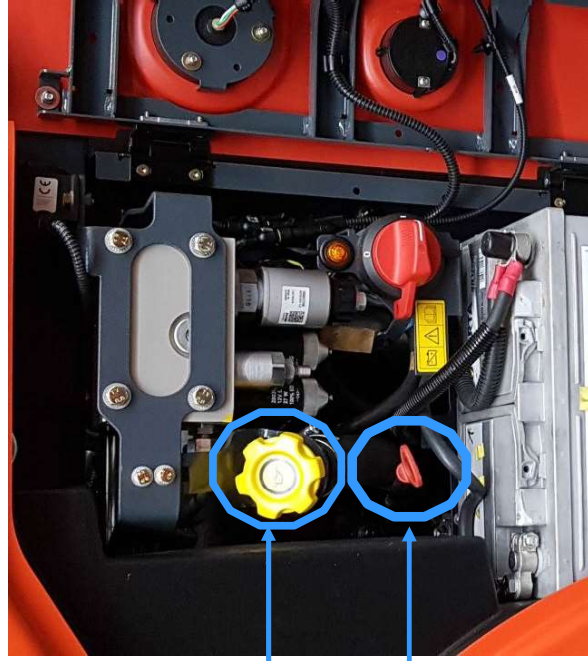

Oil filling nozzle (A)

Oil quantity when changing approx. 7.0l

Oil bearing rod (B)

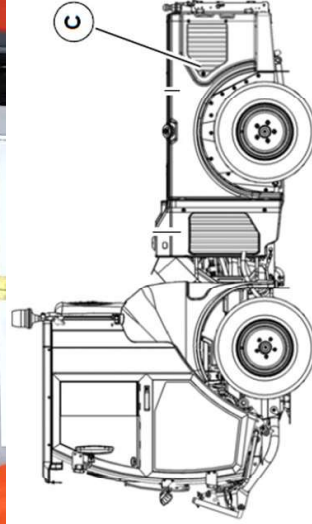
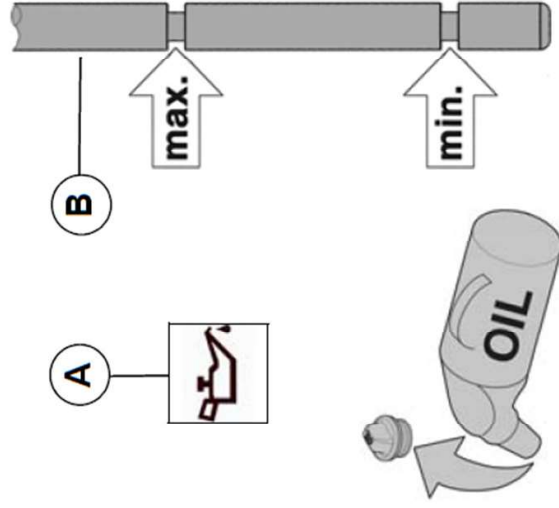

Maintenance flap (C)

Maintenance engine

Oil and fuel filter change (once at 50h and every 500h) View from left back bottom

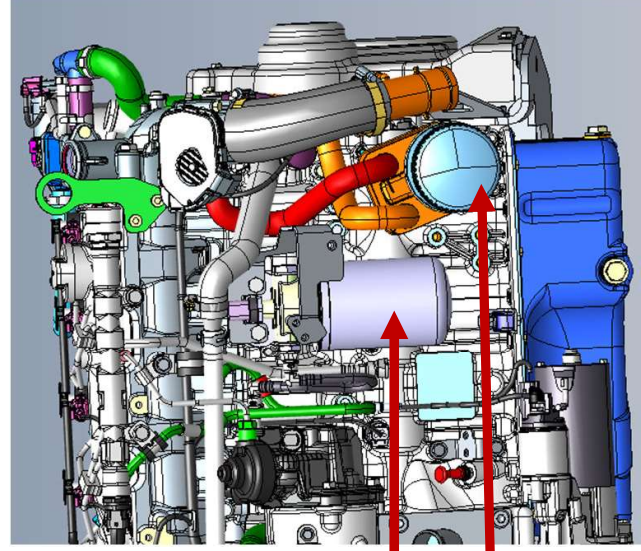

- 1 Block the fuel supply line by means of a hose clamp.
- 2 Place the appropriate vessel under the filter to absorb leaking fuel.
- 3 Unscrew the main fuel filter and dispose of it in accordance with local environmental regulations.
- 4 lightly oil the seal of the new main fuel filter.
- 5 Install the filter dry and tighten it **by hand**.
- 6 Release fuel supply line again.

Venting fuel system !

1. Insert the start key up to the stop and insert it into the position "I".

Depending on the design, the following light-ups:

- pre-glow display
- charging control
- oil pressure indicator

2. Leave the start key at the "I" position, until the electric fuel pump switch off audibly (after approx. 30 seconds).

3. Turn the start key back to position "0".
Note: Perform steps 2 and 3 multiple times to push the air out of the fuel system.

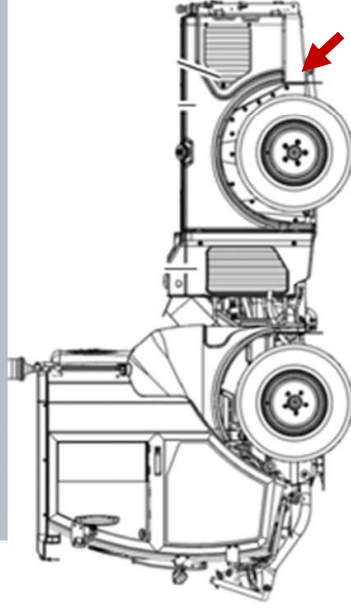

Citymaster 1650 1491.15



Maintenance engine

Oil change (once at 50h and every 500h)

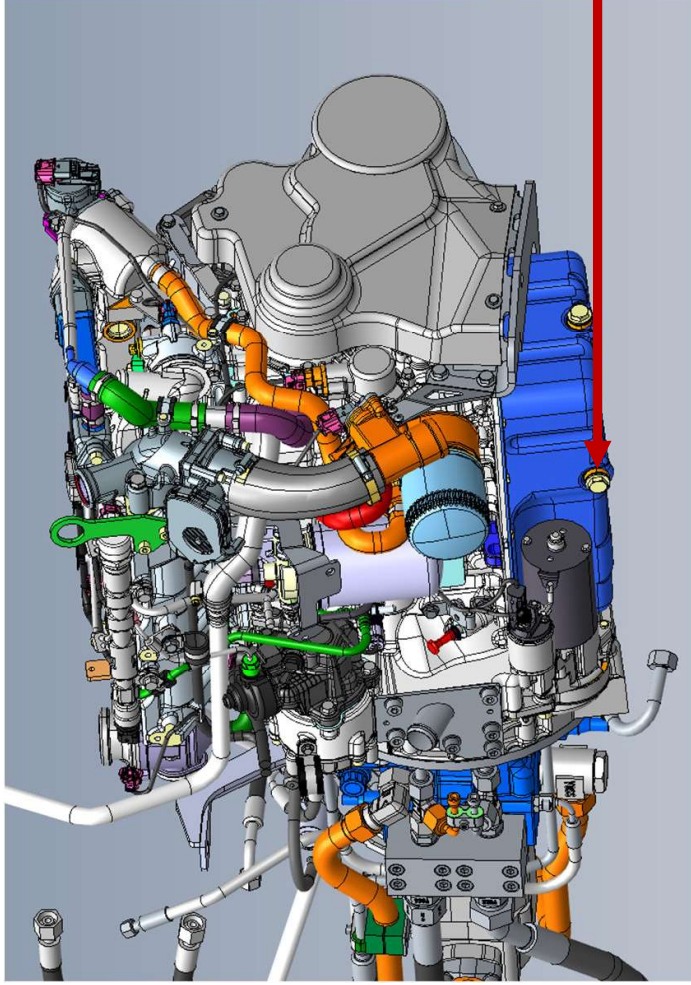

Tightening the drain screw with
50Nm
501 404 00
AM22 x 1.5 DIN7604 A3C

Replacing copper sealing ring
500 016 00
A22 x 27 DIN7603 Cu

Oil drain screw

Use this, the other is slightly higher !

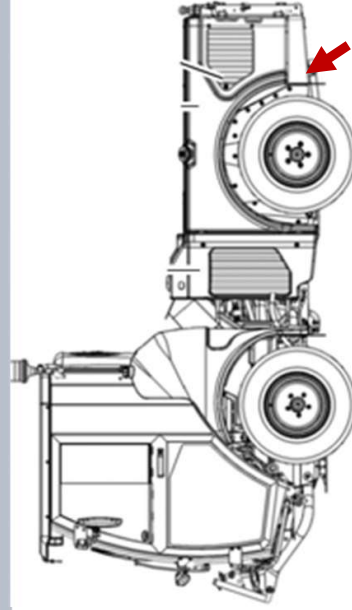

Maintenance engine

Fuel pre-filter: drain and change water (every 500h)

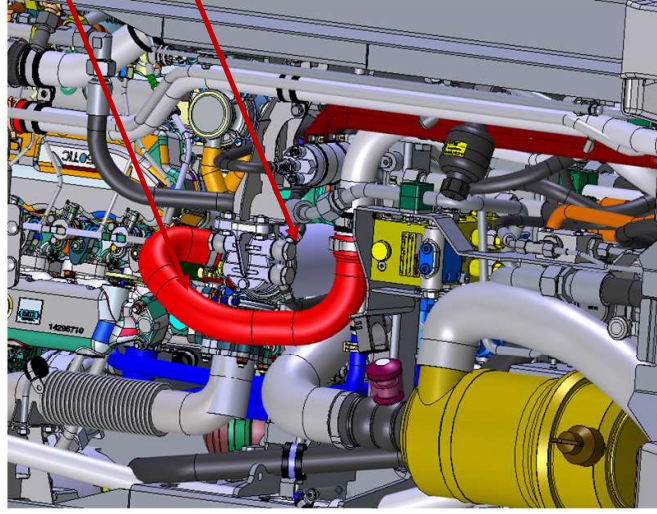

Remove air hose

Fuel pre-filter /
Water separators

- 1 Block the fuel supply line on the fuel pre-filter.
- 2 Place the appropriate vessel under the filter to absorb leaking fuel.
- 3 Unplug the cable of the water level sensor on the drain screw.
- 4 Loosen the drain screw and drain fuel.
- 5 Unscrew fuel pre-filter. Completely unscrew the drain screw with integrated water level sensor.
- 6 Dispose of used fuel pre-filters in accordance with local environmental regulations.
- 7 Clean drain screw with integrated water level sensor and lightly oil sealing surfaces. Screw the drain screw into the new fuel pre-filter.
- 8 Easily oil the seal of the new fuel pre-filter, dryly mount the filter and tighten it by hand.
- 9 Release the fuel supply line and plug in the cables of the water level sensor.

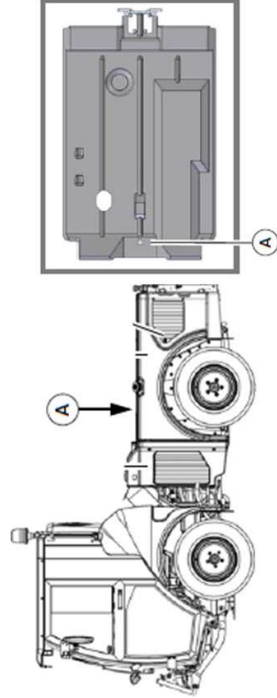

Maintenance engine

Crankcase breather: Change oil separators, replace the charge air hose (every 500h)

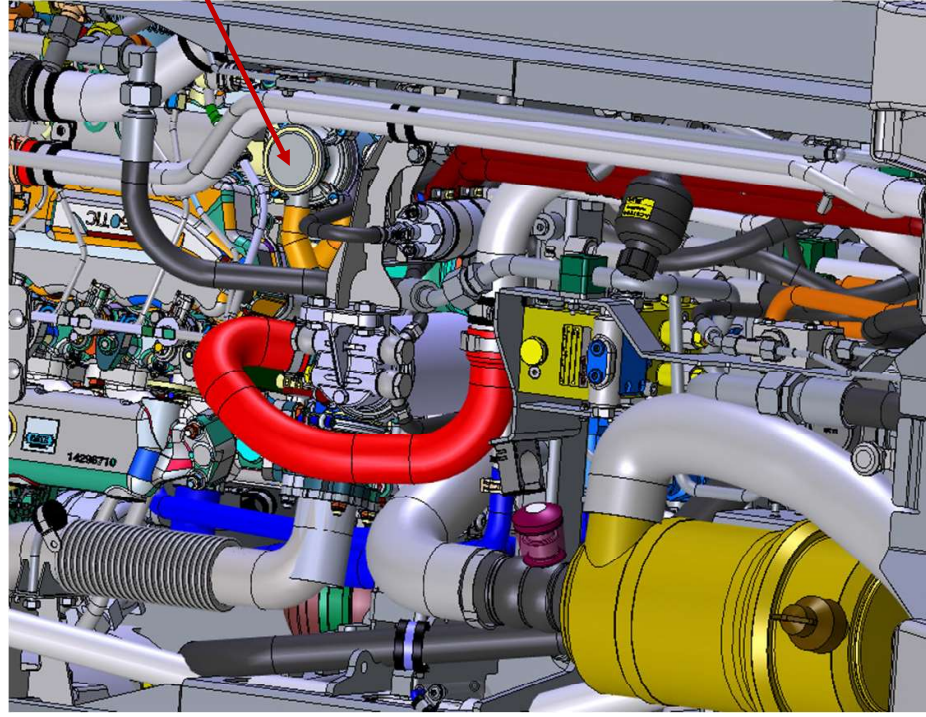

crankcase breather

- loosen the four screws (1)
- Remove the lid (2)
- Clean casing
- Replace oil separators (3)
- Putting on the lid
- tighten screws again

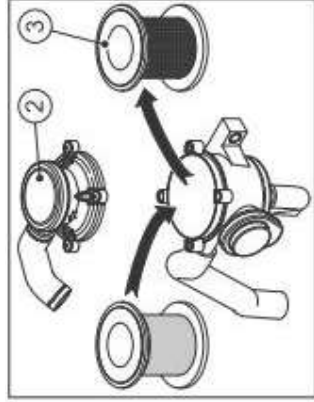
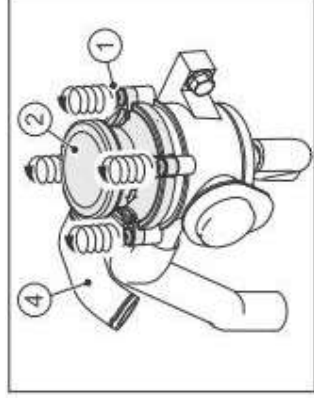

Maintenance engine

Change air filter (every 500h) and safety element (every 1000h)

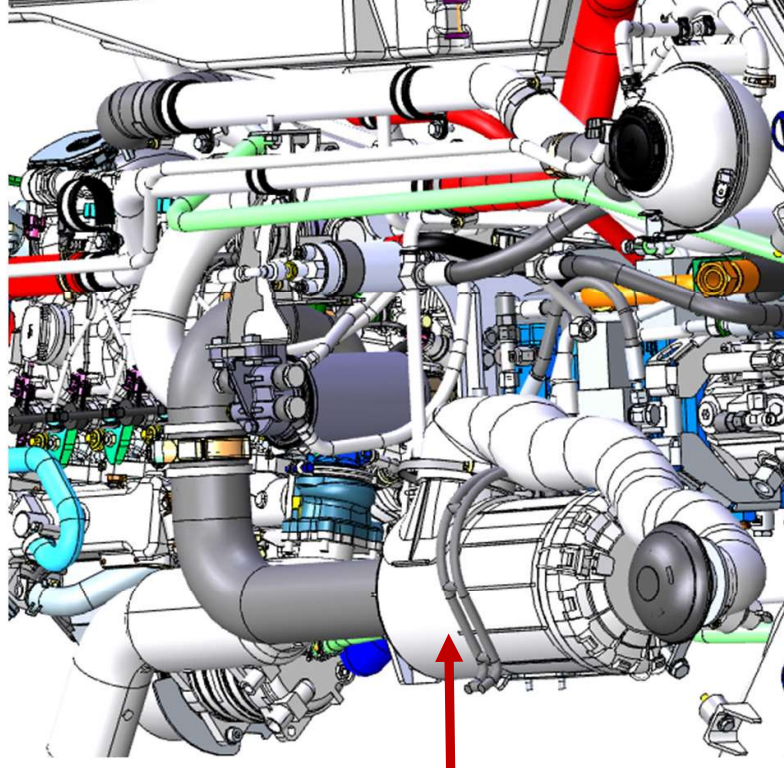

Air filters and
Safety element

- Loosen clamping element
- Tilt filter housing upwards
- Open brackets
- Remove lid
- Changing filters

Attach the clamp vertically to
the lid, sits in the middle

Maintenance engine

Check poly-V belts (every 500h) and change (no later than every 3000h)

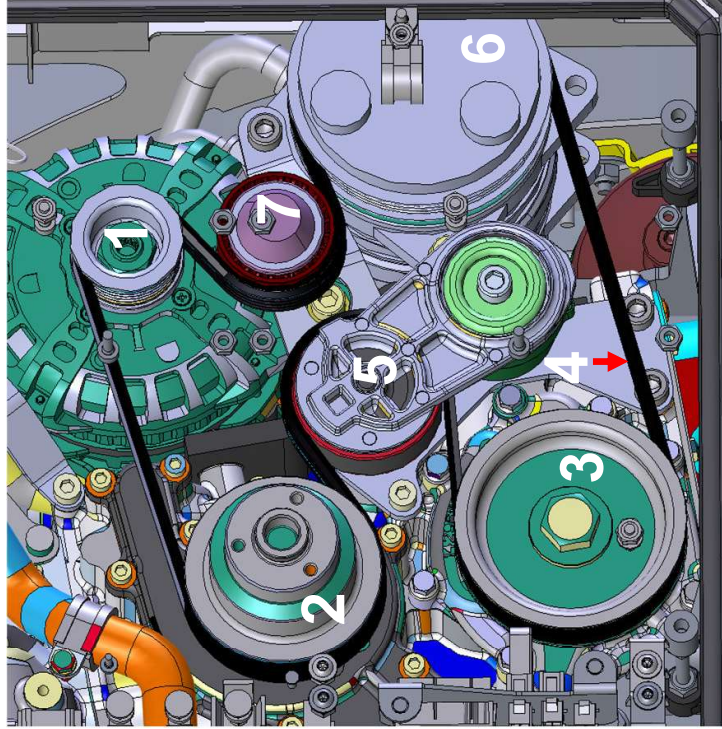

- 1. generator
- 2. water pump
- 3. crankshaft
- 4. Poly-V belt
- 5. Belt tensioner
- 6. Air-conditioning compressor
- 7. deflection roller

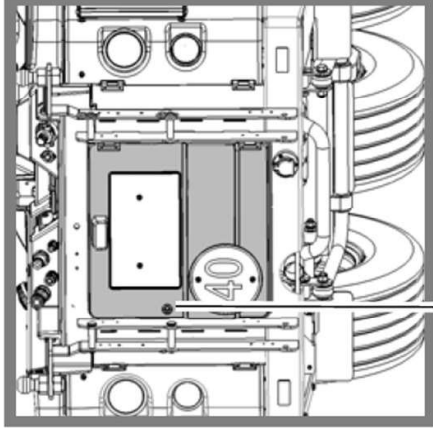

B

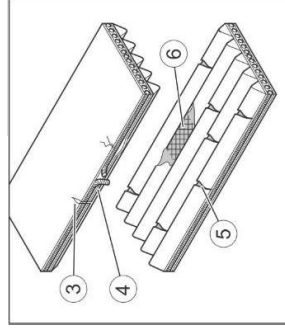
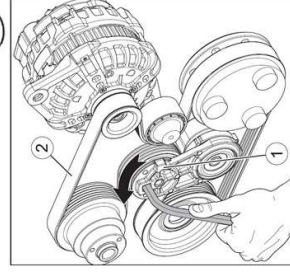

- 3 Cross cracks on the back
- 4 Frayings on the flanks
- 5 Cross cracks in several ribs
- 6 Broken rib parts

Citymaster 1650 1491.15



Maintenance engine

Change coolant (every 4 years)

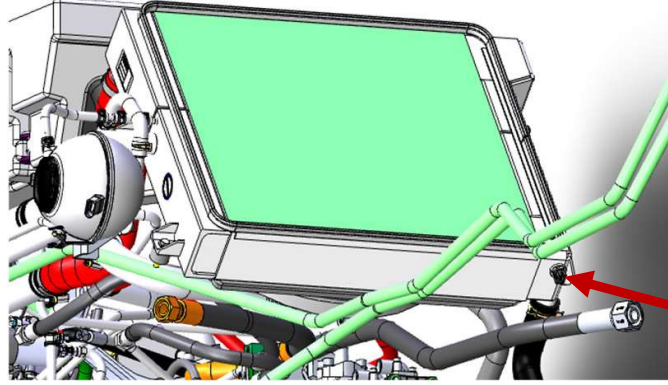

Coolant drain screw

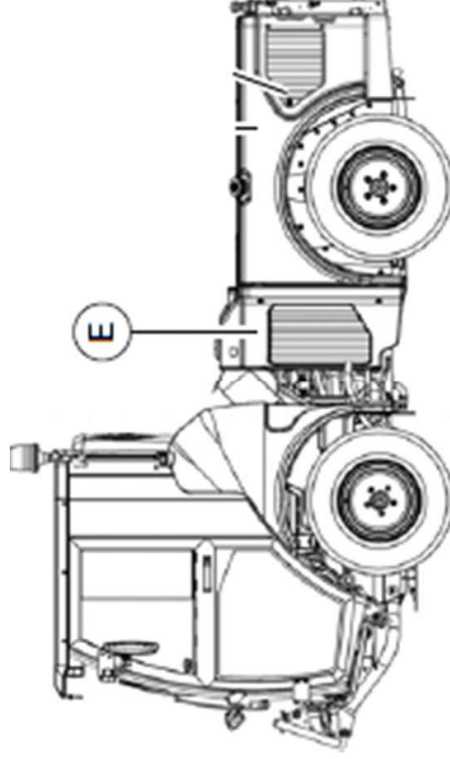

Citymaster 1650 1491.15

Maintenance engine

Change coolant (every 4 years)

For filling with coolant, we recommend a vacuum filling device for fast and bubble-free filling

Kühlerentlüfter

Art.-Nr. 0714 55 18

Zum schnellen Befüllen des Kühlersystems mit Kühlwasser ohne Lufteinschlüsse.



Technische Daten

Arbeitsdruck: 6 – 12 bar
Luftanschluss: 1/4"
Gummikonus: Ø 17 – 50 mm



Lieferumfang

- Kühlerentlüfter mit Gummikonus
- Wasserschlauch mit Sieb
- Aufbewahrungskoffer mit Bedienungsanleitung

Hako

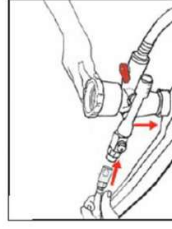

1. Druckluft an den Kühlerentlüfter anknüpfen und diesen auf die Kühleröffnung setzen.

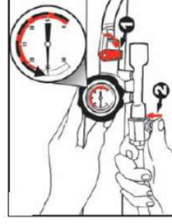

2. Sperrventil schließen, dann das Entlüftungsventil V betätigen und ausreichend Vakuum aufbauen.

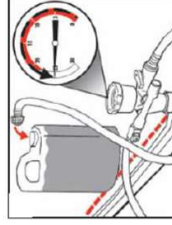

3. Den Wasserschlauch in den Behälter einführen, Behälter nicht zu tief abstellen.



4. Das Sperrventil langsam öffnen. Das Kühlwasser strömt ins Kühlersystem.

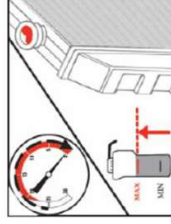

5. Kühlwasser bis zum max. Stand befüllen.

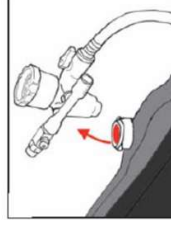

6. Den Kühlerentlüfter von der Kühleröffnung entfernen und Kühler verschließen.



7. Fahrzeug starten und den Motor kurz laufen lassen.

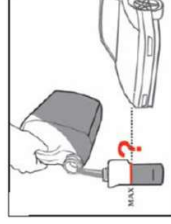

8. Falls notwendig, Kühlsystem etwas auffüllen.

Druckluft-Stecknippel

Messing

Art.-Nr. 0699 211 4

Stahl

Art.-Nr. 0699 211 41

Citymaster 1650 1491.15



Maintenance engine

Change coolant (every 4 years)

If no vacuum filling device is available, ensure that the cooling system is fully filled and ventilated.

To vent the cooling system, it is necessary to dismantle the cabin roof of the machine and open the vent valve (highest point so that the air can escape from the cooling system).

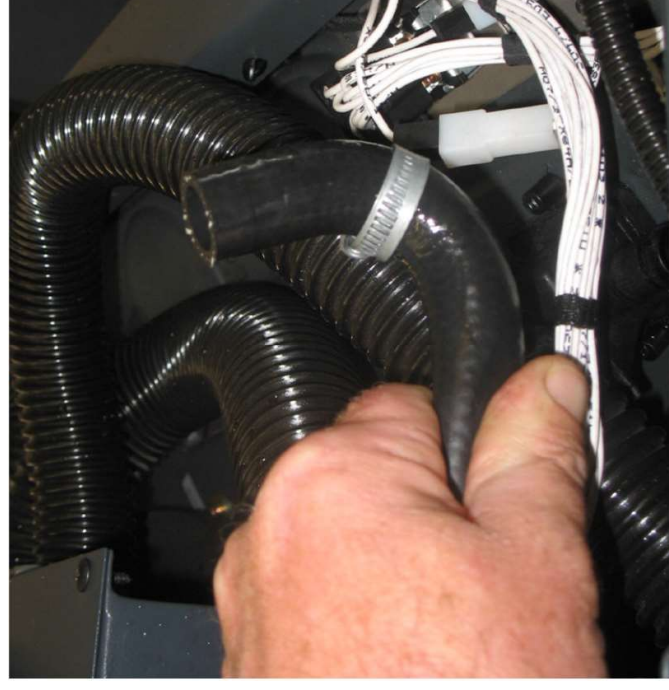
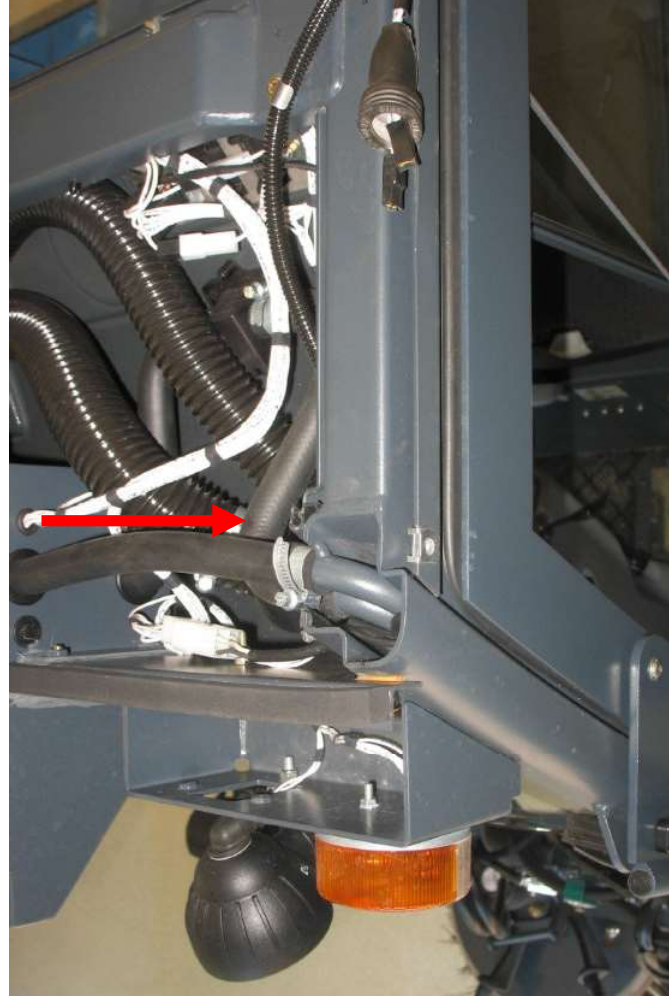

Citymaster 1650 1491.15



Maintenance engine

Change coolant (every 4 years)

Fill the coolant in the compensating container until marked.

Filling and venting can be accelerated when using a cooling system tester. The pressure build-up significantly speeds up the venting process.

After filling the system, reassemble the heating hose. Start the engine and let the motor run for at least 15 minutes when the heating valve is open. During the process, the level on the compensating container must be observed. If the coolant in the compensating tank decreases, the engine must be switched off and coolant must be refilled until the compensation tank is marked.



Citymaster 1650 1491.15



Maintenance engine

Check engine bearings (every 500h)

Check for cracks and other damage

Check torque 150 Nm

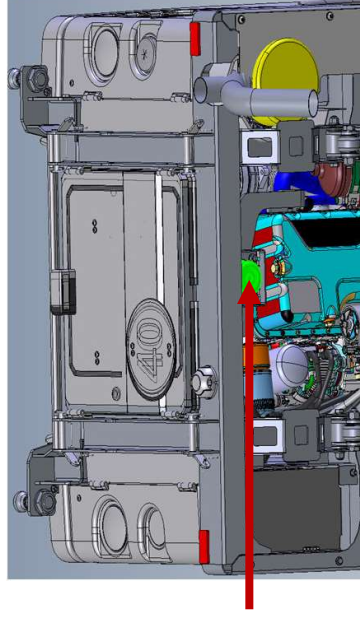
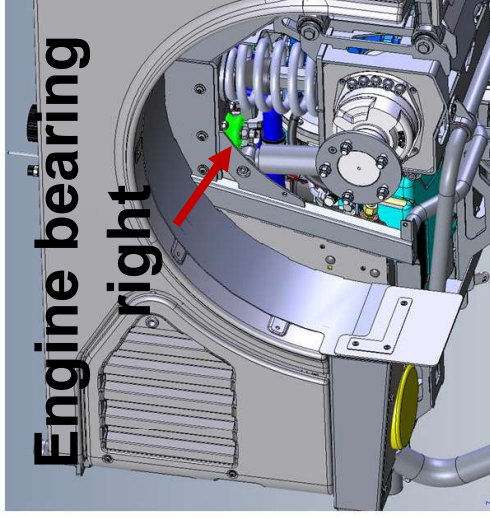
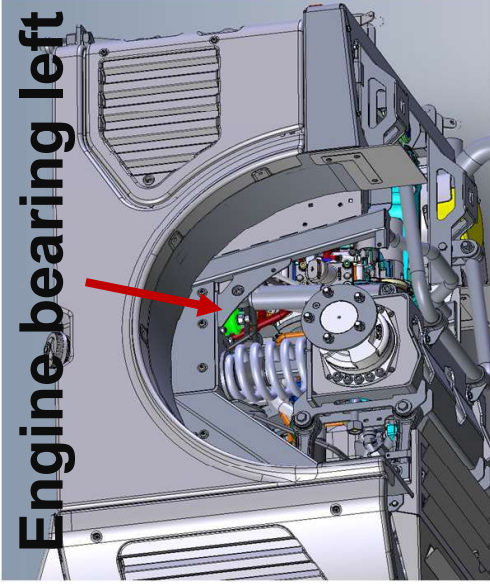

Engine bearing
rear/bottom

Citymaster 1650 1491.15

Wartungsarbeiten Motor

Motorlager prüfen (alle 500h)



Location of the engine bearings view from below

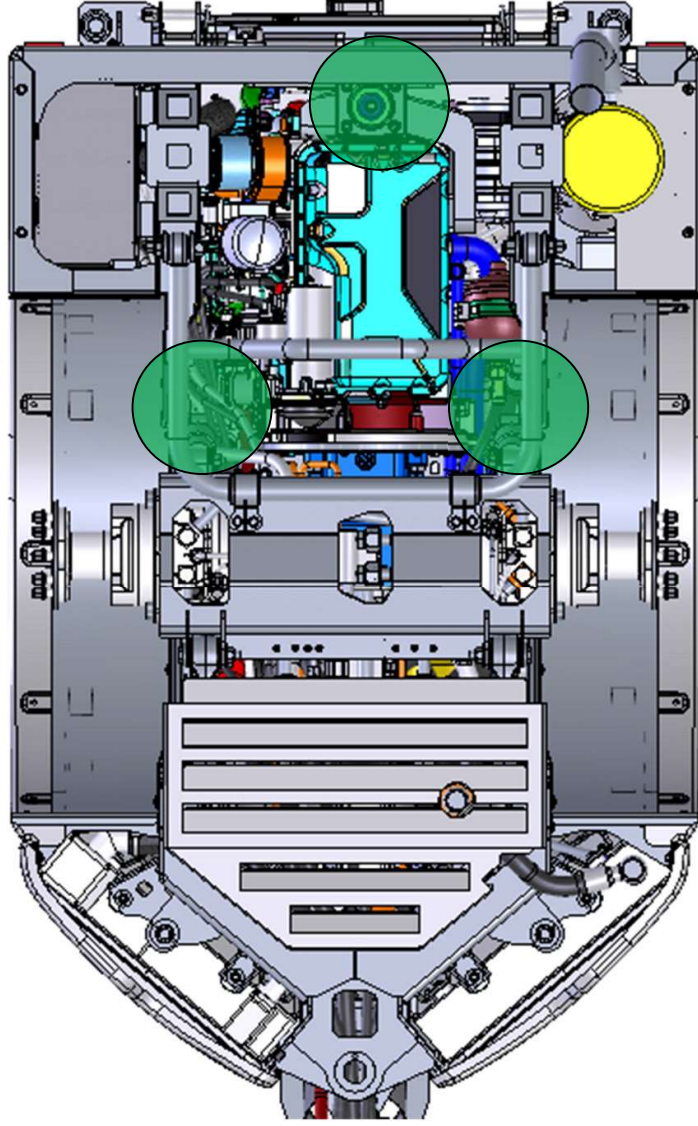



Maintenance engine

Screws check tightening moments General

Gewinde	Schraubenqualität			
	5.8	8.8	10.9	12.9
M 4	1.7	2.8	3.9	4.7
M 5	3.4	5.5	7.8	9.3
M 6	6.0	9.5	13	16
M 8	14	23	33	39
M10	29	46	65	78
M12	50	80	110	140
M14	80	130	180	220
M16	120	190	270	330
M18	170	270	380	450
M20	240	380	530	640
M22	320	510	720	860

Maintenance engine

Screws check tightening torques (every 500h)

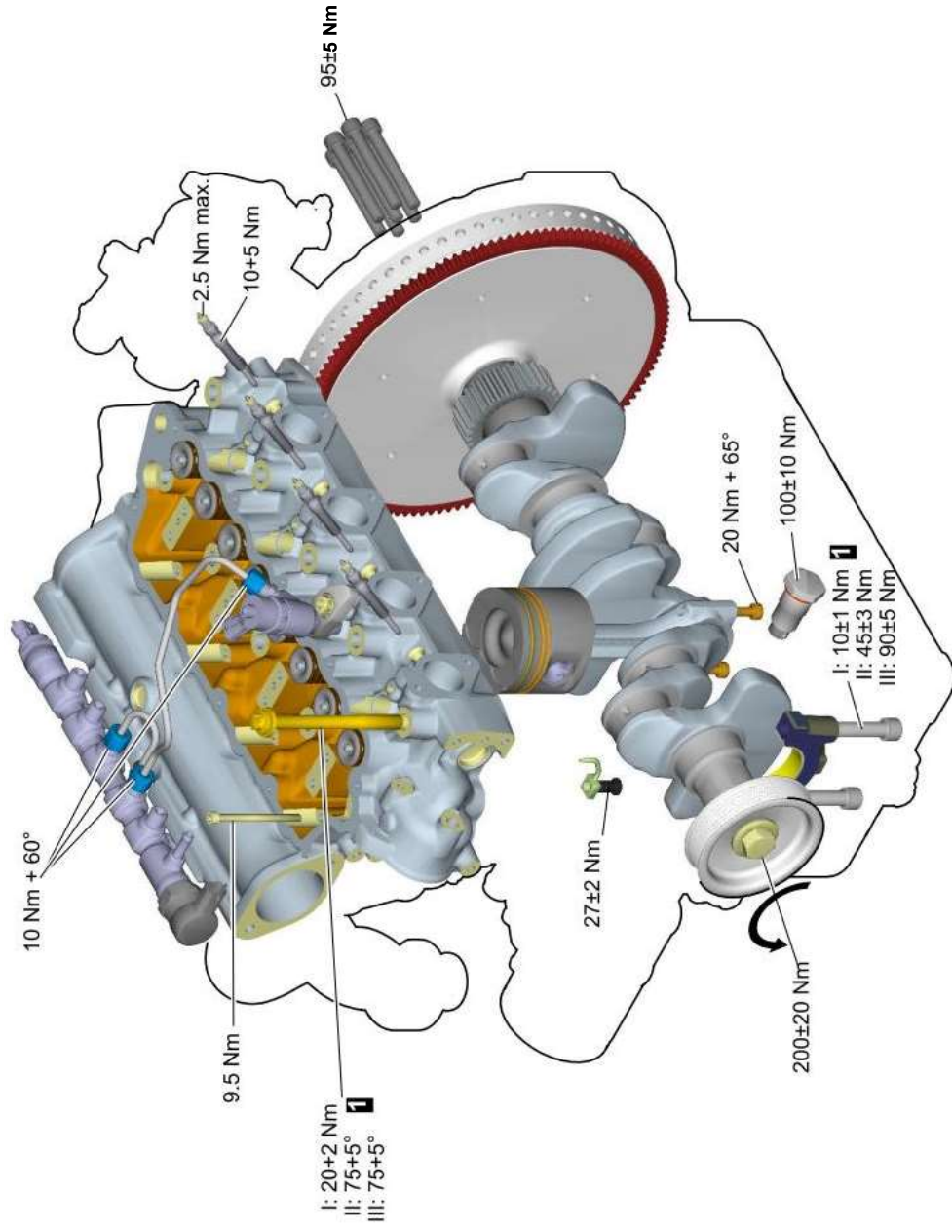

Citymaster 1650 1491.15



Maintenance engine

Screws check tightening torques (every 500h)

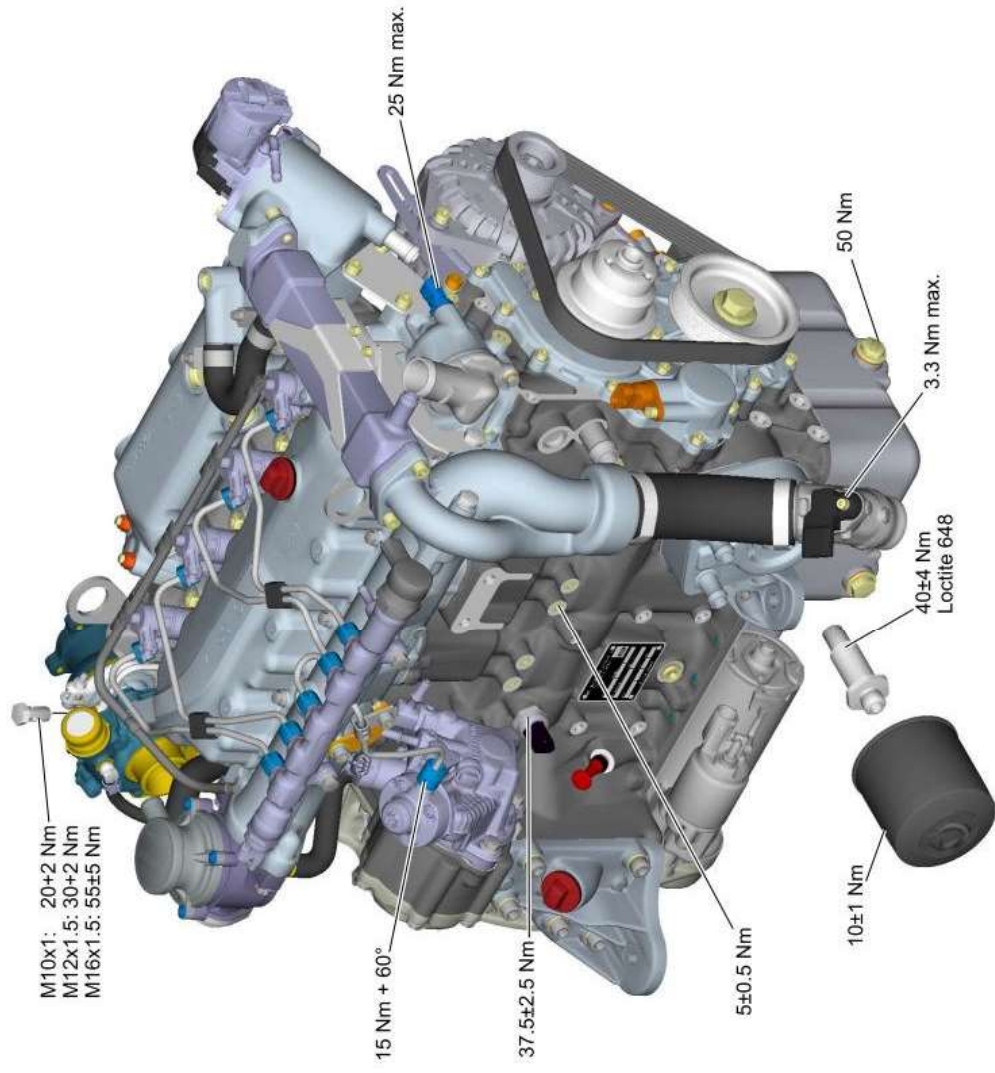

Citymaster 1650 1491.15

Maintenance engine

Clean AGR System (every 4000h)

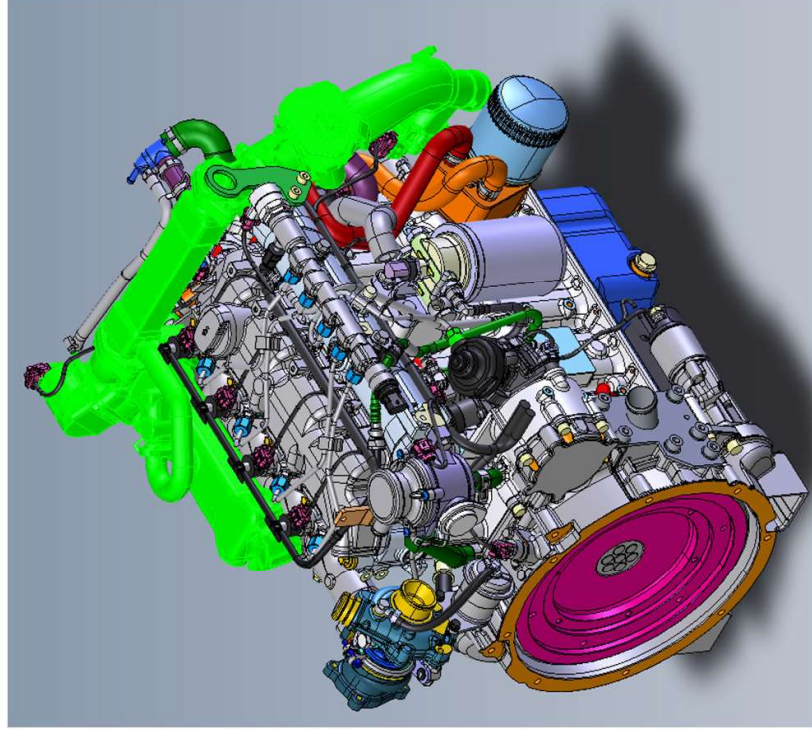

Dismantling the AGR valve and main cooler
Clean with a suitable cleaner.

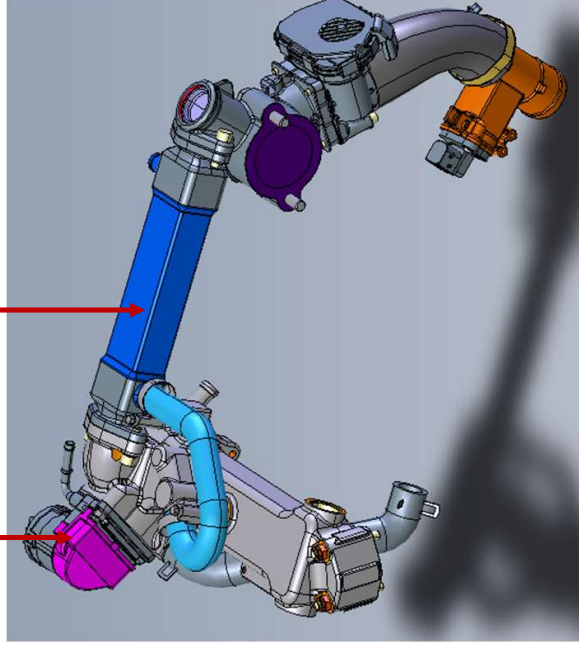

Citymaster 1650 1491.15



Wartungsarbeiten Motor

AGR System reinigen (alle 4000h)

Hint:

To ensure tension-free mounting, the mixing nozzle, the AGR cooler and the holder housing must first be pre-assembled without a suit and then tightened in the order indicated.

Anzugsreihenfolge:

- Position 1:
2 x Sechskantmutter
VM 8
23 Nm
- Position 2:
2 x Zylinderschraube
M 8x25
23 Nm
- Position 3:
2 x Zylinderschraube
M 8x25
23 Nm
- Position 4:
2 x Sechskantschraube
M 10x70
46 Nm
- Position 5:
4 x Zylinderschraube
M 8x20
23 Nm

